

M12 FEMALE 0°

PUR 3X0.34 black UL/CSA, drag ch 3m

Female straight

M12, 4-pole

Art-No. 7005 - M12 L te - (past c hexagona screw) on request

with cable sleeves

Past c housings with good resistance against chemicals and oils.

The resistance to aggressive media should be individually tested for your application. Further details on request.

Further cable lengths on request.

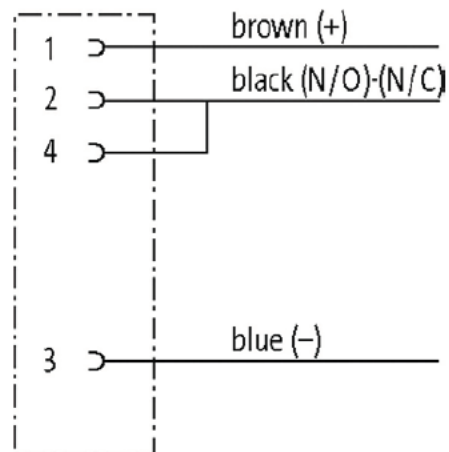
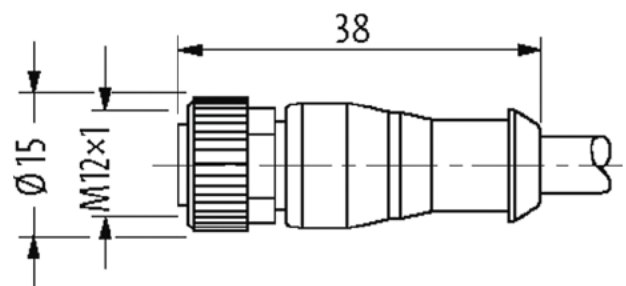
[Link to Product](#)**Illustration**

Product may differ from image

Approvals

* only for products with UL/CSA approved cable

EAC

Form

Form

2 6

General data	
Standards	D N EN 6 076 2 0 (M 2)
Mounting method	inserted tightened
Material (contact)	Copper alloy
Material (contact surface)	Au
Material (gasket)	FKM
Pollution Degree	3
Stripping length (jacket)	20 mm
Temperature range	25 +85 °C depending on cable quality
Cables	
No /diameter of wires	3× 0.34 mm ²
Wire isolation	PP (br bl bk)
C track properties	0 Mio
Material (jacket)	PUR (UL/CSA)
Outer Ø	4 mm 5%
Bend radius (moving)	0× outer Ø
Temperature range (fixed)	40 +80 °C
Temperature range (mobile)	25 +80 °C
Cable identification	633
Cable Type	3 (PUR)
Approval (cable)	cURus (AWM Style 20549/ 0493); CE conform
Cable weight [g/m]	29.70
Material (wire)	Cu wire bare
Resistor (core)	max 57 Ω/km (20 °C)
Single wire Ø (core)	0 mm
Construction (core)	42× 0 mm (multi strand wire class 6)
Diameter (core)	3× 0.34 mm ²
AWG	similar to AWG 22
Material (wire isolation)	PP
Material property (wire isolation)	CFC halogen cadmium silicone and lead free
Shore hardness (wire isolation)	70 5 D
Wire Ø incl isolation	2.5 mm 5%
Color/numbering of wires	br bk bl
Stranding combination	3 wires twisted
Shield	no
Material (jacket)	PUR
Material property (jacket)	CFC halogen cadmium silicone and lead free matt low adhesion machine easy to process abrasion resistant hydrolysis and microbial resistant
Shore hardness (jacket)	90 5 A
Outer Ø (jacket)	4 mm 5%
Color (jacket)	black
chemical resistance	good resistance to oil gasoline and chemicals (EN 608 404)
thermal resistance	flame retardant UL 58 VW / CSA FT / EC 60332 EC 60332 2 2
Nominal voltage	300 V AC
Test voltage	2500 V AC
Current load capacity	to D N VDE 0298 4
Temperature range (fixed)	40 +80 °C (+90 °C at max 0 000 operating hours)
Temperature range (mobile)	25 +80 °C (+90 °C at max 0 000 operating hours)
Bend radius (fixed)	5× outer Ø

Bend radius (moving)	0× outer Ø
No of bending cycles (C track)	max 0 Mio (25 °C)
Travel speed (C track)	max 3 m/s
Acceleration (C track)	max 0 m/s ²
Torsion stress	80°/m
No of torsion cycles	max 2 Mio (25 °C)
Torsion speed	35 cycles/min
Jacket Color	black

Technical Data

Operating voltage	max 250 V AC/DC
Operating voltage (only UL listed)	30 V AC/DC
Rated surge voltage	2.5 kV
Operating current per contact	max 4 A
No of poles	4 pole
Material group	EC 60664 category
Coding	A coded
LED display	no
Locking of ports	Screw thread (M 2× mm) recommended torque 0.6 Nm self securing
Compression gland	M 2 (SW 3)
Protection	P65 P66K P67 inserted and tightened (EN 60529)
Locking material	Zinc die casting matte nickel plated
Material	PUR
suitable for corrugated tube (internal Ø)	0 mm

Commercial data

country of origin	DE
customs tariff number	85444290
EAN	40488792 4476
eClass	272792 8
Packaging unit	

Sketch

Female

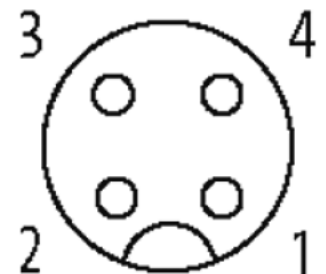

Product may differ from image